

CONTINUOUS TOTAL SULFUR ANALYZER

Reduction & Tape Method

Series 1600



General Purpose Total Sulfur Analyzer

FEATURES

- **ASTM METHOD REFERENCES**
- **CONTINUOUS ANALYSIS**
- **AUTOMATIC CALIBRATION**
- **GENERAL PURPOSE**
- **DIRECT READ LCD**
- **SINGLE LED LIGHT SOURCE**
- **DUAL PROCESSOR 100% ANALYSIS**
- **18-BIT A/D CONVERSION FOR FASTER RESPONSE, LOWER DETECTION LIMITS & LESS TAPE CONSUMPTIONS**
- **FAULT DIAGNOSTICS**
- **SPECIFIC TO SULFUR ONLY**

Description & Principle of Operation

The petrochemical, gas processing, & gas pipeline industry has for many years required an accurate, dependable, low maintenance, and cost effective sulfur analyzer for quality and process control purposes. With over twenty years of experience in developing and manufacturing sulfur analyzers and associated parts and supplies, Analytical Systems International has met these requirements with a unique & proven microprocessor based analyzer, which provides continuous on-line analysis based on the only absolutely specific lead acetate principal of operation. The Model 1600 system measures total sulfur by hydrogenation, similar to that as described in ASTM Method D3031, D4084-82, D4468-85, & 4045-81. The sulfur sample is precisely metered into a continuous flowing stream of hydrogen gas. The sample and hydrogen are heated in the furnace up to 1,315 degrees C resulting in thermal cracking of the sulfur which are reduced to short chain hydrocarbons. These reactions result in the formation of H₂S. After complete humidification of the sample the H₂S comes in direct contact with the lead acetate tape which produces a darkening of lead sulfide immediately measured by the photodiode/LED optics & rate-of-reaction digital electronics to provide an accurate and reproducible total sulfur analysis with PPB or PPM sensitivity up to 100%. The LCD display provides the current reading, any alarm condition, procedure prompts (such as calibration procedure), and failure indicators (local and remote capability). Quality materials are selected for their compatibility and are utilized throughout fabrication. Special attention is given to wetted parts that come in contact with the process stream and are selected to be non reactive with H₂S.



Analytical Systems Int'l/KECO R&D

(281) 516-3950 * FAX (281) 351-8925 * www.ASIWebPage.com * CustomerService@ASIWebPage.com
Sales@ASIWebPage.com

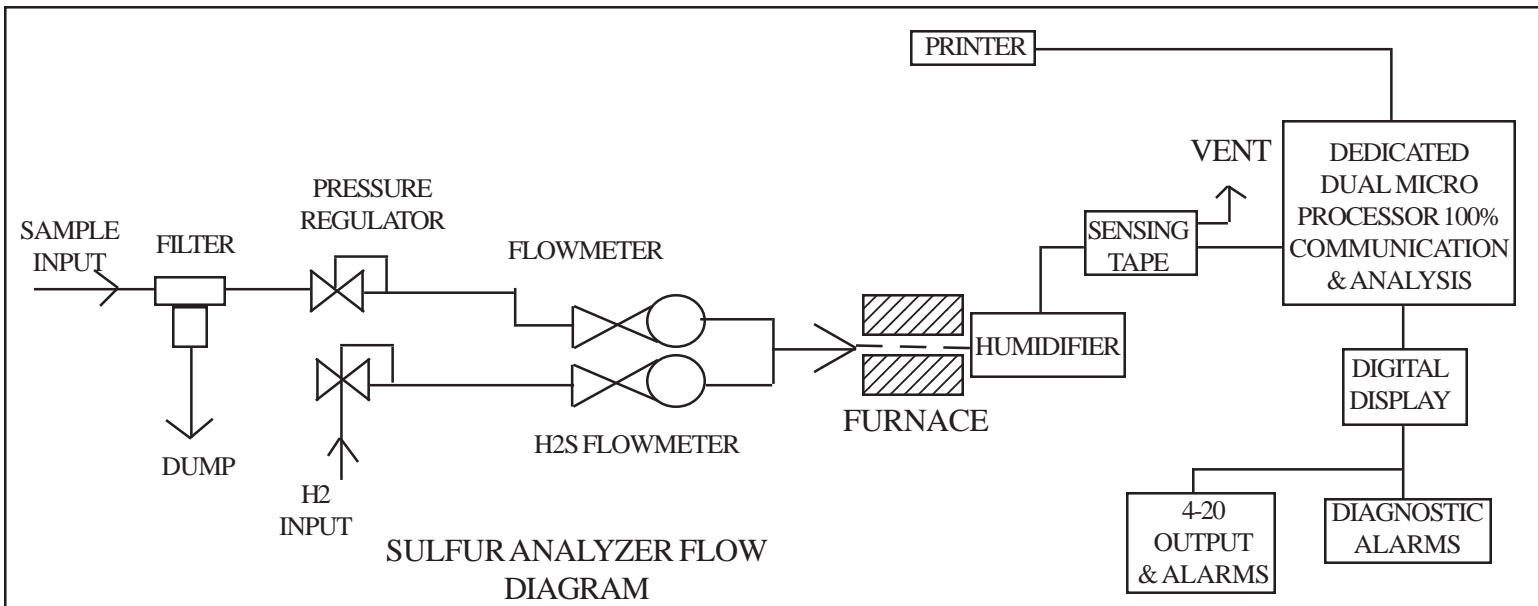

SERIES 1600 SPECIFICATIONS

POWER INPUT -CUSTOMER SPECIFIED

110/240 VAC 50/60 Hz

TEMPERATURE

5 C to 50 C (operating)

-0 C to 70 C (storage)

PERFORMANCE

Range: Customer Specified

ppb thru ppm Up to Sulfur

Resolution: 1 ppb

Accuracy: $\pm 2\%$ of Full Scale

Repeatability: $\pm 1\%$ of Full Scale

Linearity: $\pm 1\%$ of Full Scale

Drift: Less than 1% of FS

Temp. Coefficient: .01% / C

Analysis Time: Less Than 1 Second

Interference: None

AREA CLASSIFICATION

Class I, Div II Series 1700

Class I, Div I Series 1700

DISPLAY

Alpha Numeric LCD

Pixel Graphics 128x64

ANALOG

4 - 20ma Isolated (optional)

4-20ma (standard)

ALARM OPTIONS

Solid State 30ma 24V

Mechanical Relay 5a 220V

Normally Opened / Normally Closed

Diagnostic & Concentration

DIMENSIONS & WEIGHT

30"X50"X12" or 76cmX127cmX30cm

100 lbs. or 90 kg appx.

ACCESSORY OPTIONS

Automatic Calibration

Sample Probe and Regulator

Fugitive Emissions Control

Chart Recorder

Heater & Thermostat

RS-232/485

Modem Communications

Quotation Information:

Analytical Systems International provides design and application engineering assistance for the User's analyzer requirements. For a quotation, please complete ASI Analyzer Quote Request Form at www.ASIWebPage.com

PH (281) 516-3950 * FX (281) 351-8925 * www.ASIWebPage.com

Sales@ASIWebpage.com * CustomerService@ASIWebpage.com